

Neles™ NDX™ intelligent valve controller, compact model

Neles NDX compact model is the next generation intelligent valve controller. It is optimized for single acting actuators and all type of control valves in all industry areas. It guarantees end product quality in all operating conditions with incomparable performance, advanced diagnostics, and years of reliable service. The NDX is a future-proof investment with life-time support for asset management.



Total cost of ownership

- Fast and reliable installation process
- Low energy and air consumption
- Easy to use diagnostics simplify determining when valve maintenance is required
- Inherent high air capacity eliminates additional instrumentation
- One positioner that fits to all control valves; small and big, rotary and linear, single acting
- Available for intrinsically safe applications

Key features

- Reliable and robust design
- Industry leading pneumatic capacity
- Benchmark control performance
- Simple and fastest installation and commissioning
- Local / remote operation
- Valve stroke length up to 220 mm
- Local / remote operation
- Wide language support
- Expandable architecture
- HART 7 (as standard) or HART 6
- Diagnostics available in every unit, including:
 - Self-diagnostics
 - Online diagnostics
 - History trends
 - Communication diagnostics
 - Extended off-line test capabilities
- Worldwide support for hazardous area approvals

Options

- Internal position transmitter
- Gauge block

Minimized process variability

- Linearization of the valve flow characteristics
- Excellent dynamic and static control performance
- Fast response to control signal change
- Accurate internal measurements



Easy installation and configuration

- Simple / fast configuration and calibration using one of the following:
 - Standard Local User Interface (LUI) accessible without opening the device cover
 - LUI can be rotated according to mounting position
 - Distributed Control System (DCS) asset management program
- Backwards compatible with retrofit kits for easy replacement of Neles NE700 and ND9000 positioners
- Easy retro-fit to an extensive list of 3rd party control valves
- Installation to all common control systems

Open solution

- Neles is committed to delivering products that freely interface with software and hardware from a variety of manufacturers; NDX is no exception. This open architecture allows the NDX to be integrated with other field devices to give an unprecedented level of controllability.
- FDT and EDD based multi-vendor support configuration
- Support files for NDX are available from www.valmet.com/ndx

NDX mounting on actuators and valves

- Supports all single acting pneumatic actuators
- Both rotary and linear valves (up to 220 mm stroke)
- Guided startup and automatic/manual calibration

Product reliability

- Designed to operate in harsh environmental conditions
- Rugged modular design
- Excellent temperature characteristics
- Vibration and impact tolerant
- IP66 enclosure
- Protected against humidity
- Resistant to dirty air
- Wear resistant and sealed components
- Fully contactless and maintenance free position measurement

Predictive maintenance

- Easy access to collected data with any FDT/DTM software and drivers
- Intelligent diagnostics analysis to visualize control valve health and performance
- Patented on-line valve signature
- Logical trend and histogram collection
- Diagnostics collected continuously while the process is running
- Extensive set of off-line tests with accurate key figure calculations
- Clear notifications with on-line alarms

Technical description

The NDX is a 4–20 mA powered microcontroller based intelligent valve controller. The device contains a local user interface enabling configuration and operation without opening the device cover. Configuration and operation can also be made remotely by PC with asset management software connected to the control loop via HART communication.

After connections of electric signal and pneumatic supply, the micro controller continuously reads measurements:

- Input signal
- Valve position with contactless sensor
- Actuator pressure
- Supply pressure
- Device temperature

Advanced self-diagnostics guarantee that all measurements operate correctly.

Powerful microcontroller calculates a control signal for I/P converter. I/P converter (prestage) controls the operating pressure to the pneumatic relay (output stage). Pneumatic relay moves and actuator pressure changes accordingly. The changing actuator pressure moves the control valve. The position sensor measures the valve movement. The control algorithm modulates the I/P converter control signal until the control valve position is according to the input signal.

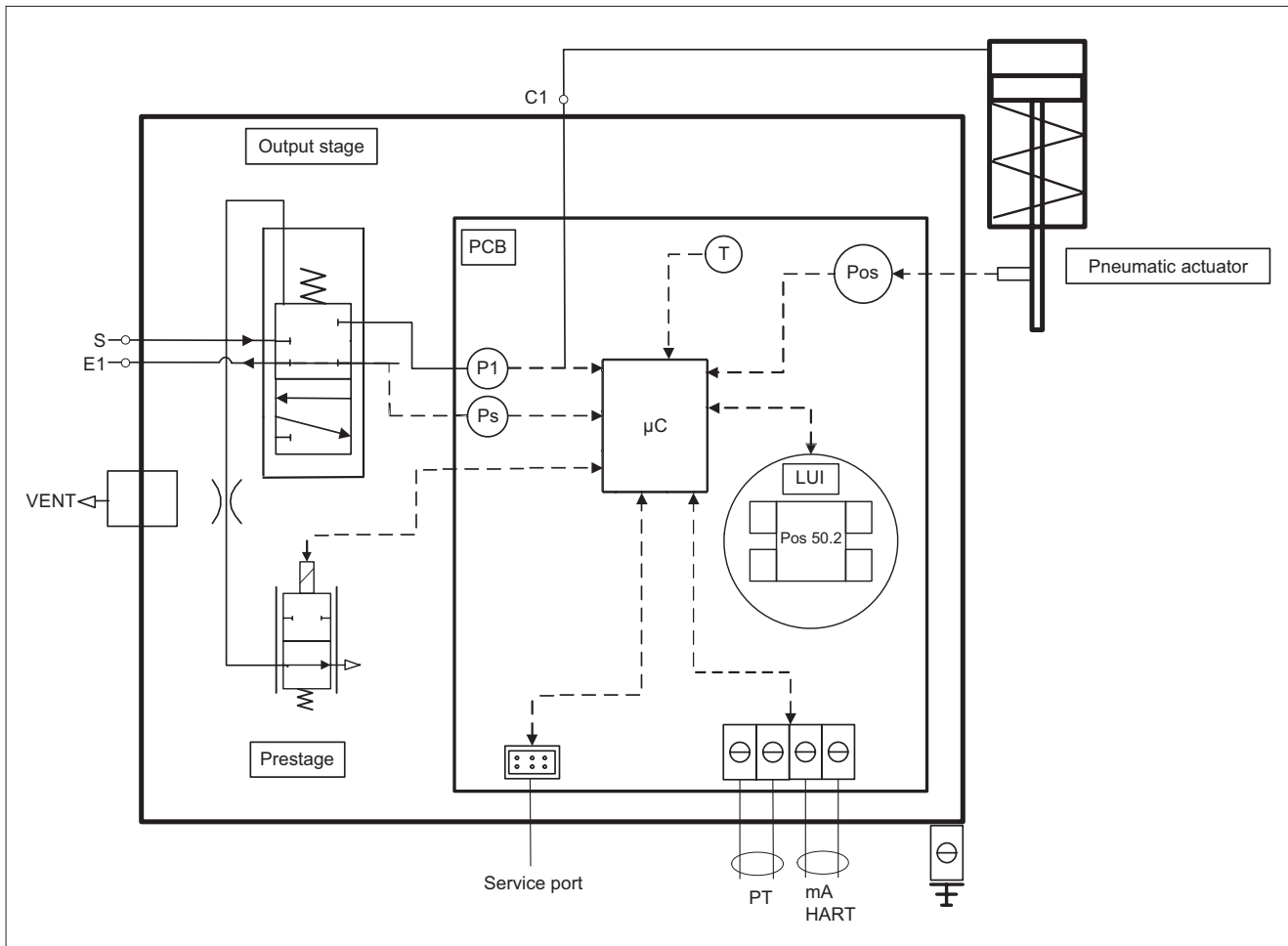

Technical specifications NDX intelligent valve controller

General

Loop powered 4-20 mA, no external power supply required.
Suitable for linear and rotary valves. Actuator connections in accordance with VDI/VDE 3845 and IEC 60534-6 standards.
Action: Single acting, direct or reverse
Travel range: Linear (standard): 5-120 mm / 0.2-4.7 in
Linear (long range): 120-220 mm / 4.7-8.6 in
Rotary: 30-160 degrees

Environmental influence

Standard temperature range: -40° – +85 °C / -40° – +185 °F
Influence of temperature on valve position:
Rotary: 0.5 % / 10 °C
Linear: 0.1 mm / 10 °C
LUI usable range: -25°C ... +65°C
Temperature cycling/Dry heat:
Acc. to IEC 60068-2-2
Humidity Limits: Acc. to IEC 61514-2
Magnetic Fields: Negligible at 30 A/m
Acc. to IEC 61000-4-8
Vibration: Tested acc. to ANSI/ISA-75.13.01-2013

Electromagnetic protection

Emission acc. to IEC 61000-6-4
Immunity acc. to EN 61000-6-2

Enclosure

Housing material: Epoxy coated anodized aluminum alloy, EN1706 AC - AlSi12 (b), copper free, Cu content max 0.4 %
Cover material: Compact - polycarbonate
Magnet holder: Linear, standard: Glass fiber reinforced polyamide, PA66GF20
Linear, long range: Anodized aluminum alloy
Rotary: Anodized aluminum alloy
Protection class: IP66, NEMA 4X
IP67 for storage and transport
Pneumatic ports:
Supply air: 1/4 NPT, G1/4 with additional block
Actuator: 1/4 NPT, G1/4 with additional block
Exhausts: 3/8 NPT, G3/8 with additional block
Cable entry: 2 pcs. 1/2 NPT (M20 with adapter)
Weight: 2.0 kg / 4.4 lbs (Compact)

Pneumatics

Supply pressure: 1.4–8 bar / 20–116 psi (single acting)
2–8 bar / 29–116 psi (double acting)
Supply media: Air, nitrogen, sweet natural gas
Effect of supply pressure on valve position: < 0.1 % at 10 % difference in inlet pressure
Air quality: Acc. to ISO 8573-1
Solid particles: Class 7 (40 µm filtration)
Humidity: Class 1 (at minimum dew point 10 °C/ 18 °F below minimum temperature is required)
Oil class: 3 (or < 1 ppm)
Air capacity¹: 80 Nm³ / h / 47.1 scfm
Air consumption in steady state position¹: 0.1 Nm³/h / 0.06 scfm

¹ rated at 4 bar / 60 PSI supply pressure

Electronics

HART Protocol rev. 7 as standard
Supply power: Loop powered, 4–20 mA
Min. signal: 3.8 mA
Min. control signal: 3.95 mA
Current max: 120 mA
Load voltage: 9.7 VDC at 20 mA
9.0 VDC at 4 mA
Impedance at 20mA: 485 Ω
Maximum voltage: 30 VDC
Rev. polarity protection: -30 VDC
Over current protection: active over 35 mA
Wire size: 0.5-2.5 mm² (14-20 AWG)

Performance with moderate constant-load actuators

Dead band: ≤ 0.2 %
Hysteresis: < 0.5 %
Linearity error: < 0.5 %
Long range: < 1.5 %
Repeatability: < 0.2 %

Local User Interface (LUI) functions

Accessible with the cover installed.

- PIN code lock to prevent unauthorized / unintended access with the cover installed or permanently (if configured)
- Guided-startup wizard
- Language selection; English, Chinese, Spanish, Italian, French, Korean, German, Turkish, Dutch, Portuguese, Japanese (pending)
- Calibration: Automatic / Manual / 1-Point
- 3-point measurement linearization
- Configuration of the control valve
 - Actuator type & valve type
 - Valve dead angle
 - Safety cut-off range
 - Input signal direction
 - Positioner fail action
- Monitoring of valve position, target position, input signal, temperature, supply and actuator pressure
- Manual control of the valve from Local User Interface

Note: LUI usable temperature range is -30° to +60 °C

Position transmitter (optional)

Output signal: 4–20 mA (galvanic isolation; 600 VDC)
Supply voltage: 12–30 VDC
Linearity: < 0.05 % FS
Temperature effect: < 0.35 % FS
Failsafe output: 3.5 mA or 22.5 mA
Maximum external load: 690 Ω for I.S.
Ex ia IIC T6 Ui ≤ 28 V

Approvals and electrical values

Approval	EC Type examination	Electrical values	Temperature ranges
II 1 G Ex ia IIC T6 ... T4 Ga II 1 D Ex ia IIIC T ₂₀₀ 85 °C ... T ₂₀₀ 115 °C Da	EESF 21 ATEX 018X EN IEC 60079-0:2018/ A11:2024 EN 60079-11:2012 IEC 60079-11:2023 Edition 7.0	Input: Ui ≤ 28 V, Ii ≤ 120 mA, Pi ≤ 1 W, Ci ≤ 3.7 nF, Li ≤ 10.9 μH. Output: Ui ≤ 28 V, Ii ≤ 120 mA, Pi ≤ 1 W, Ci ≤ 3.7 nF, Li ≤ 10.9 μH. external load resistance 0–690 Ω NAMUR-DO1, NAMUR-DO2 Ui ≤ 16 V, Ii = 25 mA, Pi = 100 mW, Ci = 23.4 nF, Li = 27.8 μH	T4: -40 °C ... +80 °C; T5: -40 °C ... +65 °C; T6: -40 °C ... +50 °C
II 2 G Ex ib IIC T6 ... T4 Gb II 2 D Ex ib IIIC T ₂₀₀ 85 °C ... T ₂₀₀ 115 °C Db IP66	EESF 21 ATEX 019X EN IEC 60079-0:2018/ A11:2024 EN 60079-11:2012 IEC 60079-11:2023 EN 60079-7:2015/ A11:2024	Input: Ui ≤ 28 V, Ii ≤ 120 mA, Pi ≤ 1 W, Ci ≤ 3.7 nF, Li ≤ 10.9 μH. Output: Ui ≤ 28 V, Ii ≤ 120 mA, Pi ≤ 1 W, Ci ≤ 3.7 nF, Li ≤ 10.9 μH. external load resistance 0–690 Ω NAMUR-DO1, NAMUR-DO2 Ui ≤ 16 V, Ii = 25 mA, Pi = 100 mW, Ci = 23.4 nF, Li = 27.8 μH Input values for type of protection "ec": Ui ≤ 28 V (mA and PT loop) Ui ≤ 16 V (NAMUR-DO1, NAMUR-DO2)	T4: -40 °C ... +85 °C; T5: -40 °C ... +65 °C; T6: -40 °C ... +50 °C
Ex ia IIC T6 ... T4 Ga Ex ia IIIC T20085 °C ... T200115 °C Da Ex ib IIC T6 ... T4 Gb Ex ib IIIC T20085 °C ... T200115 °C Db Ex ic IIC T6 ... T4 Gc Ex ic IIIC T85 °C ... T115 °C Dc Ex ec IIC T6 ... T4 Gc IP66	IECEX EESF 21.0014X IEC 60079-0:2017 IEC 60079-11:2023 IEC 60079-11:2011 IEC 60079-7:2017	Input: Ui ≤ 28 V, Ii ≤ 120 mA, Pi ≤ 1 W, Ci ≤ 3.7 nF, Li ≤ 10.9 μH. Output: Ui ≤ 28 V, Ii ≤ 120 mA, Pi ≤ 1 W, Ci ≤ 3.7 nF, Li ≤ 10.9 μH. external load resistance 0–690 Ω NAMUR-DO1, NAMUR-DO2 Ui ≤ 16 V, Ii = 25 mA, Pi = 100 mW, Ci = 23.4 nF, Li = 27.8 μH	T4: -40 °C ... +80 °C; T5: -40 °C ... +65 °C; T6: -40 °C ... +50 °C
II 2GD Ex db IIC T6 ... T4 Gb Ex tb IIIC T85 °C ... T113 °C Db IP66	Sira 17ATEX1283X EN 60079-0: 2012 (+A11:2013) EN 60079-1: 2014 EN 60079-31:2014	Input: 4-20 mA, Ui ≤ 30 V Output: 4-20 mA, Ui ≤ 30 V	T4: -40 °C ... +85 °C; T5: ≤ +72 °C; T6: ≤ +57 °C
Ex db IIC T6 ... T4 Gb Ex tb IIIC T85 °C ... T113 °C Db IP66	IECEX SIR 17.0069X IEC 60079-0: 2011 IEC 60079-1: 2014-06 IEC 60079-31: 2013	Input: 4-20 mA, Ui ≤ 30 V Output: 4-20 mA, Ui ≤ 30 V	T4: -40 °C ... +85 °C; T5: ≤ +72 °C; T6: ≤ +57 °C

Approval	CSA certificate number	Electrical values	Temperature ranges
Class I, Division 1, Groups A, B,C,D T4/T5/T6 Class II, Division 1, Groups E, F, G T ₂₀₀ 85°C to T200115°C Class III Division 1 T ₂₀₀ 85°C to T ₂₀₀ 115°C Ex ia IIC T4/T5/T6 Ga Ex ia IIIC T ₂₀₀ 85°C to T ₂₀₀ 115°C Da Class I, Zone 0, AEx ia IIC T4/T5/T6 Ga Class I, Zone 20, AEx ia IIIC T ₂₀₀ 85°C to T ₂₀₀ 115°C Da type 4X IP66	80095494 CAN/CSA C22.2 No. 60079-0:2019 CAN/CSA C22.2 No. 60079-11:2014 CAN/CSA C22.2 No. 60079-7:2016 +AMD1 :2018 UL 60079-0:2019 Ed 7.0 UL 60079-11:2013 Ed 6.0 UL 60079-7:2017 Ed 5.0 CSA C22.2 No. 61010-1-12, UPD1: 2015, UPD2: 2016, AMD1: 2018 UL 61010-1, 3rd Edition (2012) Amd1: 2018 CSA C22.2 No.94.2:20, 3rd Ed UL50E, 3rd Ed (2020)	Input and PT loop: Ui ≤ 28 V, Ii ≤ 120 mA, Pi ≤ 1.0 W, Ci ≤ 3.7 nF, Li ≤ 10.9 μH DO loop: Ui ≤ 16 V, Ii ≤ 25 mA, Pi ≤ 100 mW, Ci ≤ 23.4 nF, Li ≤ 27.8 μH NDX---0 intrinsically safe when installed as per F105207 NDX---1 and NDX---2 intrinsically safe when installed as per F105208	For "ia" or "ib": T6: -40°C ... +50°C or T20085°C T5: -40°C ... +65°C or T200100°C T4: -40°C ... +80°C or T200115°C For "ic" or "ec": T6: -40°C ... +50°C or T20085°C T5: -40°C ... +65°C or T200100°C T4: -40°C ... +85°C or T200115°C
Class I, Division 2, Groups A, B, C, and D; T4/T5/T6 Ex ec IIC T4/T5/T6 Gc Class I, Zone 2 AEx ec IIC T4/T5/T6 Gc type 4X IP66		Input and PT loop: Umax ≤ 28V DO loop: Umax ≤ 16 V	



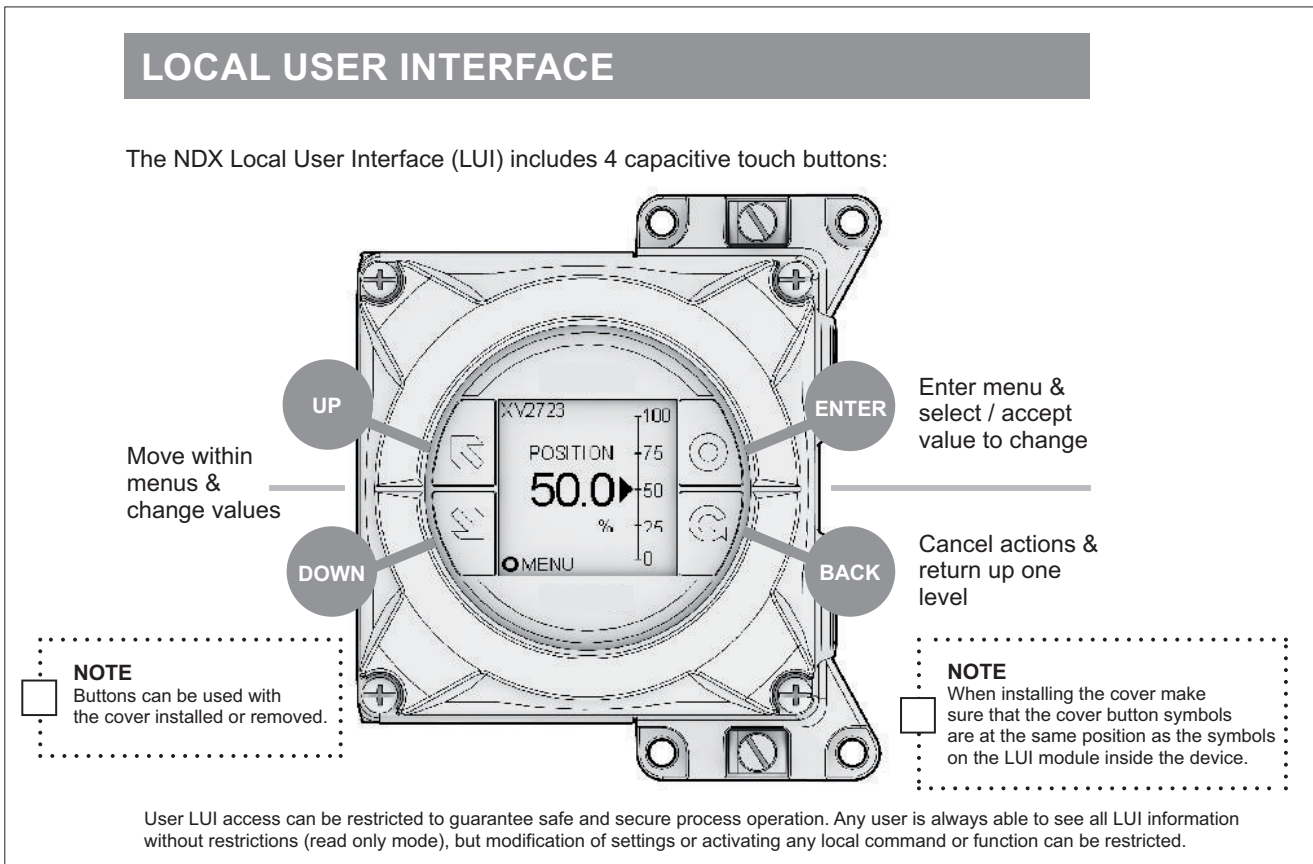

Fig. 1. Local User Interface (LUI) enables easy parameterization and calibration without opening device cover. It also gives real time awareness of control parameters in the device at a glance.

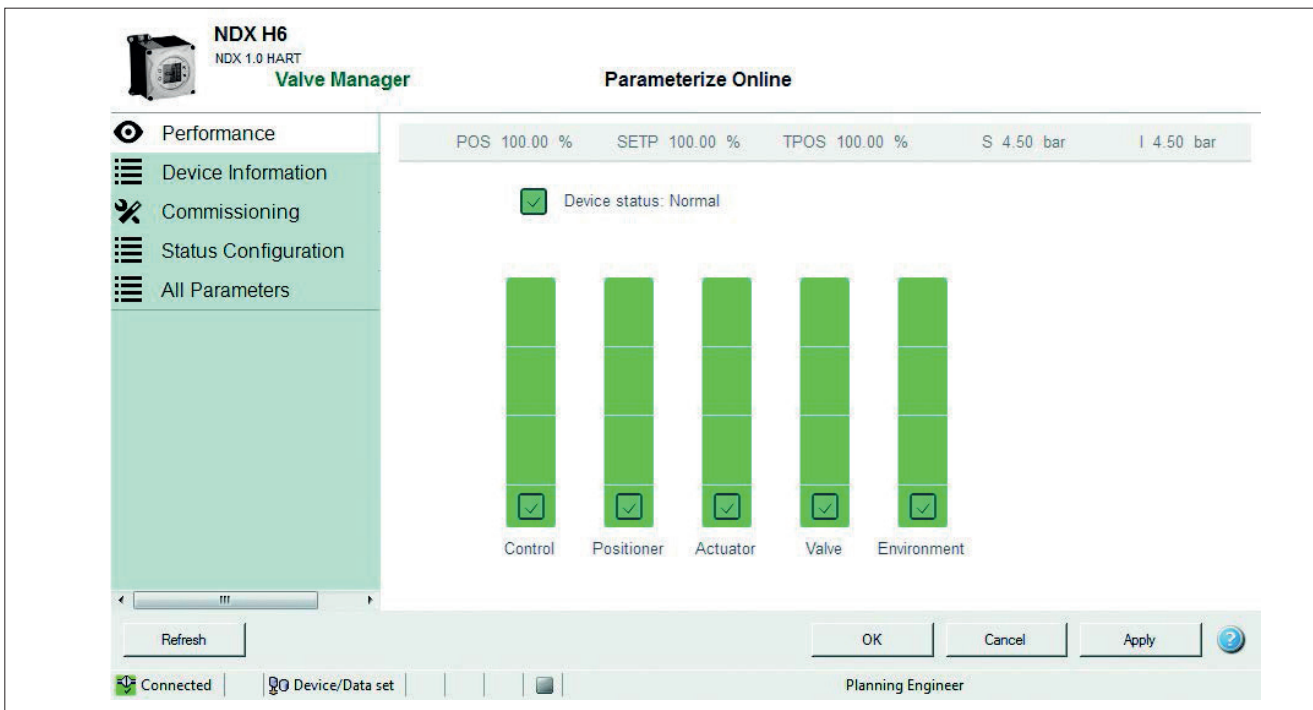
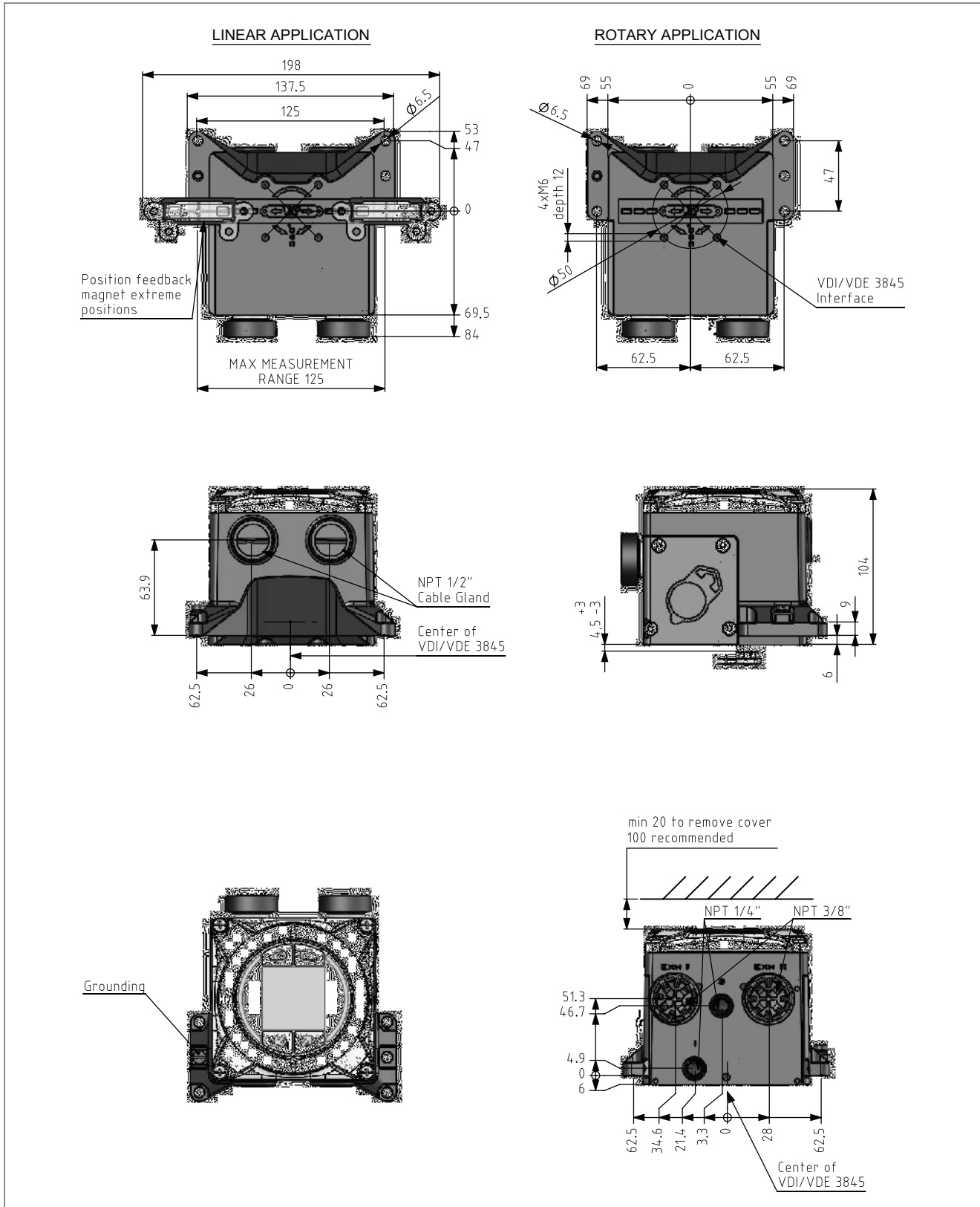
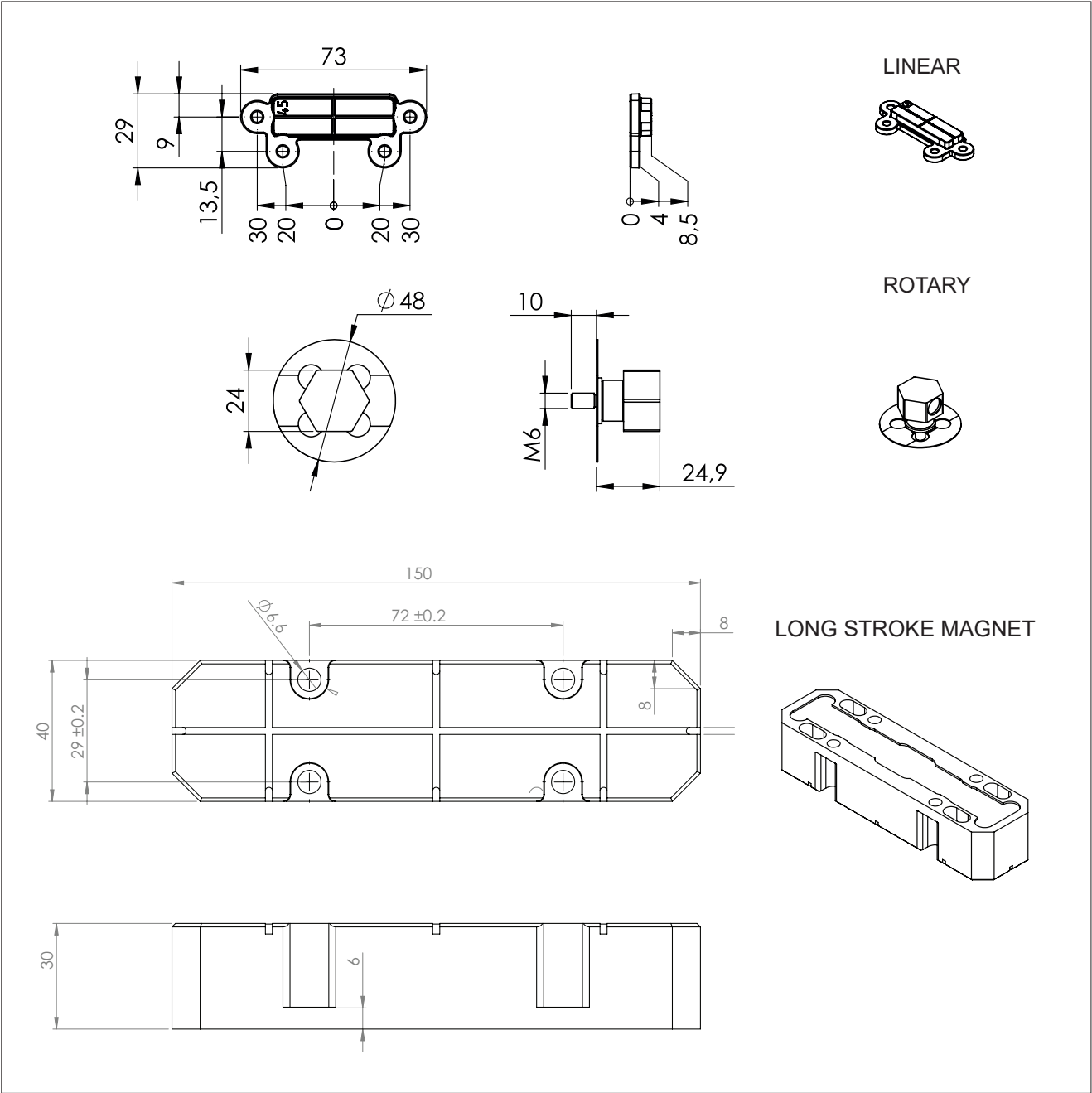

Fig. 2. The Performance View of the Neles Valve Manager graphically displays indexes of the valve, actuator and positioner, as well as indexes of control performance and the application environment. Report will show explanations of the status of each component and guidelines for recommended actions.

Dimensions

NDX1510_





NDX1510_ with gauges

NDX1510_

Gauge block module

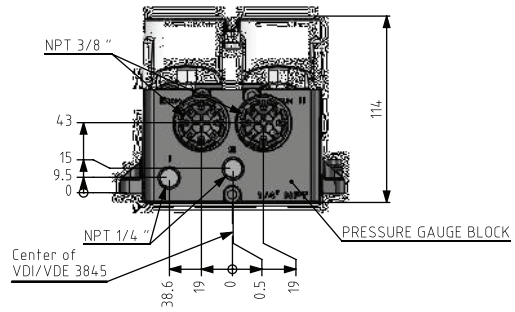
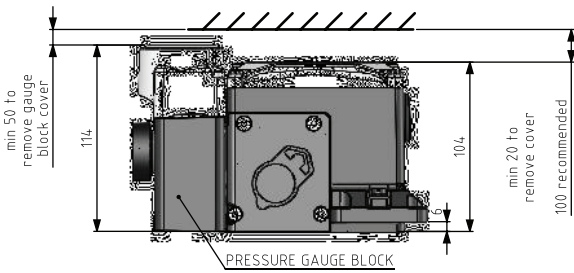
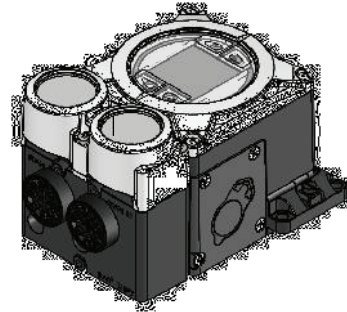
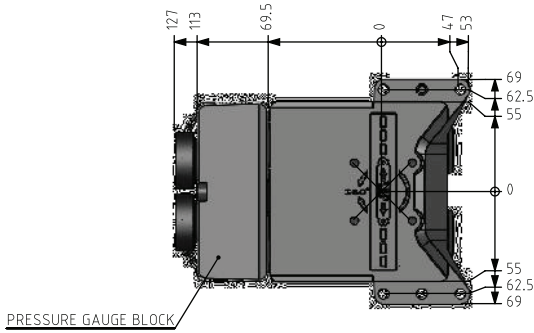

How to order intelligent valve controller NDX

1. sign																				PRODUCT GROUP Intelligent Valve Controller Series NDX Compact Model	
2. sign	1																			PNEUMATIC ACTION Single Acting	
3. sign	5																			PNEUMATIC CAPACITY Normal Capacity (80 Nm ³ /h)	
4. sign	1																			FAIL ACTION Fail safe	
5. sign	0																			ENCLOSURE IP66 / NEMA 4X. 1/2 NPT conduit entry, 2 pcs Compact - Epoxy coated anodized aluminum housing with polycarbonate cover. Applicable to 2. sign "1"	
6. sign	H T																			COMMUNICATION / INPUT SIGNAL RANGE 4-20 mA with HART communication 4-20 mA with HART + PT Internal 2-wire (passive) position transmitter. Analog position feedback signal, output 4-20 mA, supply voltage 12 - 30 V DC	
7. sign	G																			TEMPERATURE RANGE General: -40 ... +85 °C / -40 ... +185 °F	
8. sign	-																			SHALL ALWAYS BE HYPHEN OR SLASH Default option	
9. sign	N X																			APPROVALS FOR HAZARDOUS AREAS 1 If approvals are selected for both signs 9. and 10., keep the order shown below, e.g. XC type shall be selected instead of CX type. If there is no need for dual approval, sign 9. or 10. shall be N. No approval ATEX and IECEx certifications: II 1 G Ex ia IIC T6...T4 Ga II 1 D Ex ia IIIC T ₂₀₀ 85 °C...T ₂₀₀ 115 °C Da IP66 II 2 G Ex ib IIC T6...T4 Gb II 2 D Ex ib IIIC T ₂₀₀ 85 °C...T ₂₀₀ 115 °C Db IP66 T4 or T115: -40°C...+80°C; T5 or T100: -40°C...+65°C; T6 or T85: -40°C...+50°C II 3 G Ex ic IIC T6...T4 Gc II 3 G Ex ec IIC T6...T4 Gc II 3 D Ex ic IIIC T85 °C...T115 °C Dc IP66 T4 or T115: -40°C...+85°C; T5 or T100: -40°C...+65°C; T6 or T85: -40°C...+50°C	
NDX	1	2	3	4	5	6	7	8	9	10	11	12	13	14	15	16	17	18	19	20	SAMPLE MODEL CODE (char = 21)
	1	2	3	4	5	6	7	8	9	10	11	12	13	14	15	16	17	18	19	20	

Additional accessories

CONDUIT ENTRY NIPPLES

CE10	M20x1,5 conduit entry nipples Brass 1/2NPT / M20x1,5 (H5407)
CE52	M20x1,5 conduit entry nipples AlMgSi1 Anodized 1/2NPT / M20x1,5 (H140515)

CABLE GLANDS

CG51	1/2NPT for NDX (H142731, grey/plastic)
CG8	1/2NPT for NDX (code H6813, blue/plastic)
CG17	1/2NPT for NDX (For armored cable, inner OD 8-12mm / outer OD 11-16mm), Ex d / Ex e, (H7130, BRASS+ENP)

PRESSURE GAUGES AND CONNECTION BLOCKS

Pressure gauges in modules GB21, GB22, GB24, GB25: scale 0-12 bar/psi/kPa (bar/psi/ kg/cm²), AISI304 housing, polycarbonate lens, oil filled. Temperature range -55...+85 °C / -67...+185 °F.
Material of pneumatic connection block is AlSiMg, painted grey in blocks GB21, GB22, GB23, GB24, GB25

GB21	Two pressure gauges with connections 1/4 NPT (S, C2). Use with single acting NDX and explosion proof or standard housing (NDX1512_ / NDX1511_). Gauges AISI304, block AlSiMg. H158773
GB22	Three pressure gauges with connections 1/4 NPT (S, C1, C2). Use with double acting NDX and explosion proof or standard housing (NDX2512_ / NDX2511_). Gauges AISI304, block AlSiMg. H158774
GB23	Connection block module without gauges. Converts NDX pneumatic connections to G1/4. Use with both single and double acting NDX and explosion proof or standard housing (NDX1511_ / NDX1512_ / NDX2511_ / NDX2512_). H158775
GB24	Two pressure gauges with connections G1/4 (S, C2). Converts also NDX connections to G1/4. Use with single acting NDX and explosion proof or standard housing (NDX1512_ / NDX1511_). Gauges AISI304, block AlSiMg. H158776
GB25	Three pressure gauges with connections G1/4 (S, C1, C2). Converts also NDX connections to G1/4. Use with double acting NDX and explosion proof or standard housing (NDX2512_ / NDX2511_). Gauges AISI304, block AlSiMg. H158777

DRIVER SETS FOR ACTUATORS

DS51	Feedback set for NDX on linear actuators. Includes the magnet and a carrier for the magnet. For stroke lengths 5-120 mm. (H137410)
DS52	Feedback set (driver set) for NDX on VDI actuators. Includes the magnet and parts needed for attachment to actuator shaft. (H142751).
DS54	Feedback set (driver set) for NDX on long stroke linear actuators. Includes the rotary-linear adapter (H243234). Requires a separate lever arm, based on the actuator stroke length. Contact Valmet for different options.
DS55	Feedback set for NDX on linear long stroke actuators. Includes the magnet and a carrier for the magnet. For stroke lengths 120-220 mm. (H243231)

MOUNTING SETS for NDX / Linear Neles VD series actuators

Mounting sets between the NDX valve controllers and linear Neles VD series actuators, including bracket and feedback system.

MS51	Neles VD 25, stroke length 20 mm. AISI 316. (H134414)
MS52	Neles VD 29, stroke length 20-40 mm. AISI 316. (H134388)
MS53	Neles VD 37, stroke length 20-50 mm. AISI 316. (H134392)
MS54	Neles VD 48/55_R, stroke length 40-80 mm. AISI 316. (H134368)

3RD PARTY MOUNTING SETS for NDX / Linear actuators

Mounting sets between the NDX valve controllers and 3rd party linear actuators, including bracket and feedback system.

MS61	Mounting set for NDX / linear actuators, attachment face according to IEC 60534-6, stroke length 10-120 mm. AISI316. (H134584)
MS62	Masoneilan 37/38 actuators, sizes 9...15. AISI316. (H138350)
MS63	Masoneilan 87/88 actuators, sizes 6...23. Stroke length 12-64 mm. AISI316. (H134156)
MS64	Fisher 657/667 sizes 30...34, stroke length 19-29 mm. AISI316. (H134202)
MS65	Fisher 657/667 sizes 40...50, stroke length 38-51 mm. AISI316. (H138348)
MS66	Fisher 657/667 sizes 70...87, stroke length 76-102 mm. AISI316. (H138349)

3RD PARTY MOUNTING SETS for NDX / Rotary actuators

Mounting sets between the NDX valve controllers and rotary actuators, including bracket and feedback system.

MS81	Mounting set for rotary actuators with VDI/VDE 3845 attachment face, also Neles B-series actuators B1CU/B1JU 6...11. Attachment dimensions 80X30-20 (VDI1). (H141553)
MS82	Mounting set for rotary actuators with VDI/VDE 3845 attachment face. Attachment dimensions 80X30-30 (VDI 2). (H141561)
MS83	Mounting set for rotary actuators with VDI/VDE 3845 attachment face, also Neles B-series actuators B1CU/B1JU 12...20. Attachment dimensions 130X30-30 (VDI3). (H141563)
MS84	Mounting set for rotary actuators with VDI/VDE 3845 attachment face. Attachment dimensions 130X30-50 (VDI 4). (H141562)

IMOs for NDX

NDX delivery includes the Quick Guide only. The IMO is available in electronic format via www.valmet.com/ndx. If a printed IMO is required with the delivery, use the following.

IM01	NDX IMO English. 7NDX71_EN. (H137441)
IM02	NDX IMO Chinese. 7NDX71_ZH. (H143226)

Valmet Flow Control Oy

Vanha Porvoontie 229, 01380 Vantaa, Finland.

Tel. +358 10 417 5000.

www.valmet.com/flowcontrol

Subject to change without prior notice.

Neles, Neles Easyflow, Jamesbury, Stonel, Valvcon and Flowrox, and certain other trademarks, are either registered trademarks or trademarks of Valmet Oyj or its subsidiaries in the United States and/or in other countries.

